

RF Handheld Remote

PHR03

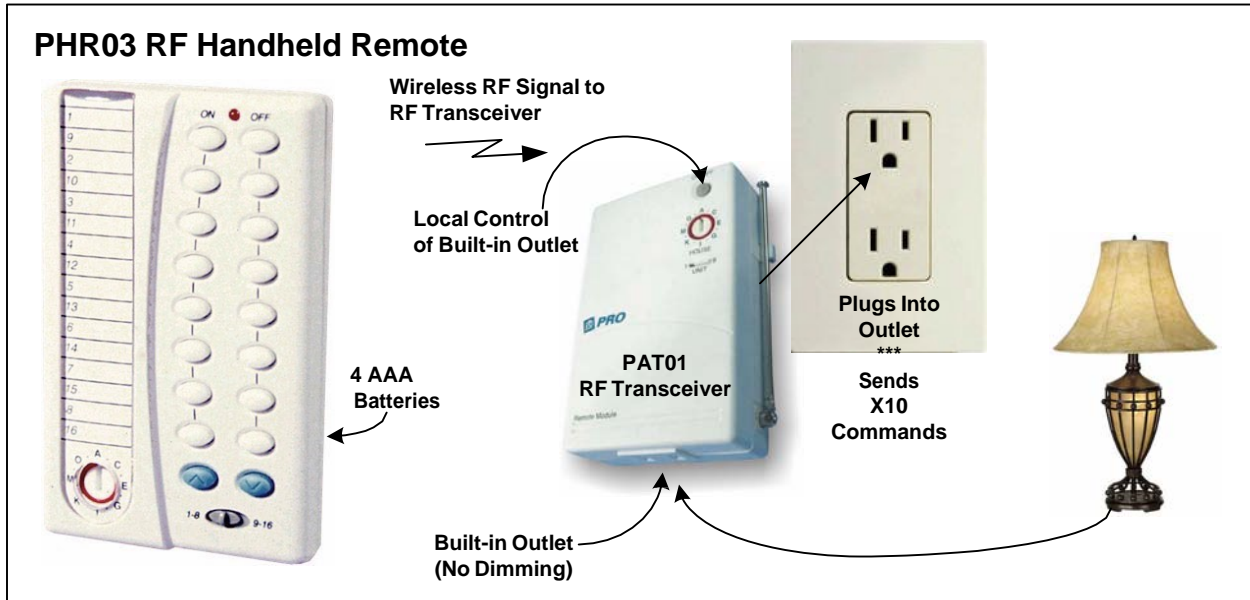

Description: The RF Handheld Remote (PHR03) used with the PAT01 RF Base Transceiver expands your X10 Remote Control capability. Control your lights and appliances all around your house without leaving your sofa! Just plug-in the RF Base Transceiver (PAT01) into any nearby outlet, and you'll have total wireless control of any electrical device connected to an X10 Receiver Module. The RF Handheld Remote Control operates as many as 16 devices (or groups of devices) and includes Dimming and Brightening buttons for use with X10 Dimmable Receiver Modules. The plug-in Base Transceiver receives the Commands and instantly sends them along the home's power lines. The system uses Radio Frequency (RF) Signals instead of Infrared (IR), so you won't have to be in direct line-of-sight for proper operation. As long as the RF Handheld Remote is within 100 feet (ideal conditions) of the plug-in Base Transceiver, it will work like a charm! The RF Handheld Remote requires 4 AAA batteries, which are sold separately.

Specific Requirements:

RF Handheld Remote requires 4 AAA batteries, which are sold separately.
PAT01 - RF Base Transceiver Module sold separately.

Optional / Supplementary Devices & Modules:

PLW01 Standard Incandescent Wall Switch Module, PLM01 Plug-in Lamp Module, PAM01/02 Plug-in 2 and 3-pin Appliance Modules

X10 Protocol:

House Code Dial - Letters A-P, Default "A" **Unit Number Dial** - Numbers 1-16, Default "1"

Each X10 Receiver Module is set to a unique Unit Number or to an identical Unit Number as desired.

Each X10 Controller operating a specific set of Receiver Modules must be set to the same House Code as the Receivers they are controlling.

Electrical Protocol:

Nearly all residential homes are wired SPLIT-PHASE. Each 120V Phase is NOT directly connected with the other 120V phase. If after installation, an X10 Receiver does not respond to a remote Controller, then check to ensure that the breaker serving the X10 Receiver is on the same phase as the Controller. If not, the breaker can be changed to the opposite phase. An alternative solution is recommended, to install a Phase Coupler for improving remote communications throughout the home. See www.x10pro.com, then select Technical Support and PLC Troubleshooting.

Installation:

1. Install 4 AAA Batteries into the Remote Controller, careful to point batteries in the correct direction.
2. Rotate the House Code Dial on the face of the Remote to the desired Letter matching all the installed Modules.
3. Set the RF Handheld Remote Slide Switch to (1-8) to operate Units 1-8 or set it to (9-16) to operate Units 9-16.
4. Plug in and set the (PAT01) RF Base Transceiver's House Code Dial to match the House Code on the RF Handheld Remote that will be used.
5. Set the UNIT Slide Switch to "1" to control the built-in Outlet, from a Wireless Transmitter or Controller sending an X10 "A1" Command, or set the Switch to "9" to control the built-in Outlet with an X10 "A9" Command. The UNIT Slide Switch has no effect on control of all 16 Unit Numbers from the X10 PRO Handheld Remote Control (PHR03).

You are now able to operate your installed X10 Receiver Modules installed throughout the home by pressing the appropriate button ON or OFF on the Remote that corresponds to a specific Module. If that Module is a dimming Module, then a Bright or DIM Command can be pressed after the initial ON Command telling the Module to adjust its intensity level.

NOTE: To Print new Label for the PHR03 Channels, RUN ActiveHome Pro Software. Select from top Menu Bar: FILE, PRINT, Type of Report, Controller Labels. ActiveHome Pro can be downloaded from www.x10pro.com, Tech Support.

Note: As with all RF transmitter devices; electrical fields, metal doors or door window frames and appliances can cause interference that can decrease the strength of the transmitted signal. Re-locating the PAT01 RF Base Transceiver may increase your ability to receive the necessary X10 Signals from the PHR03.

2 YEAR LIMITED WARRANTY x10.com (X10), a division of Authinx Inc., warrants this product to be free from defective material and workmanship for a period of 2 years from the original date of purchase at retail. X10 agrees to repair or replace, at its sole discretion, a defective product if returned to X10 within the warranty period and with proof of purchase. If service is required under this warranty:

Call 1-888-384-0969, visit www.x10.com, or email support@x10.com