

Wire-in Filter 20A

XPF

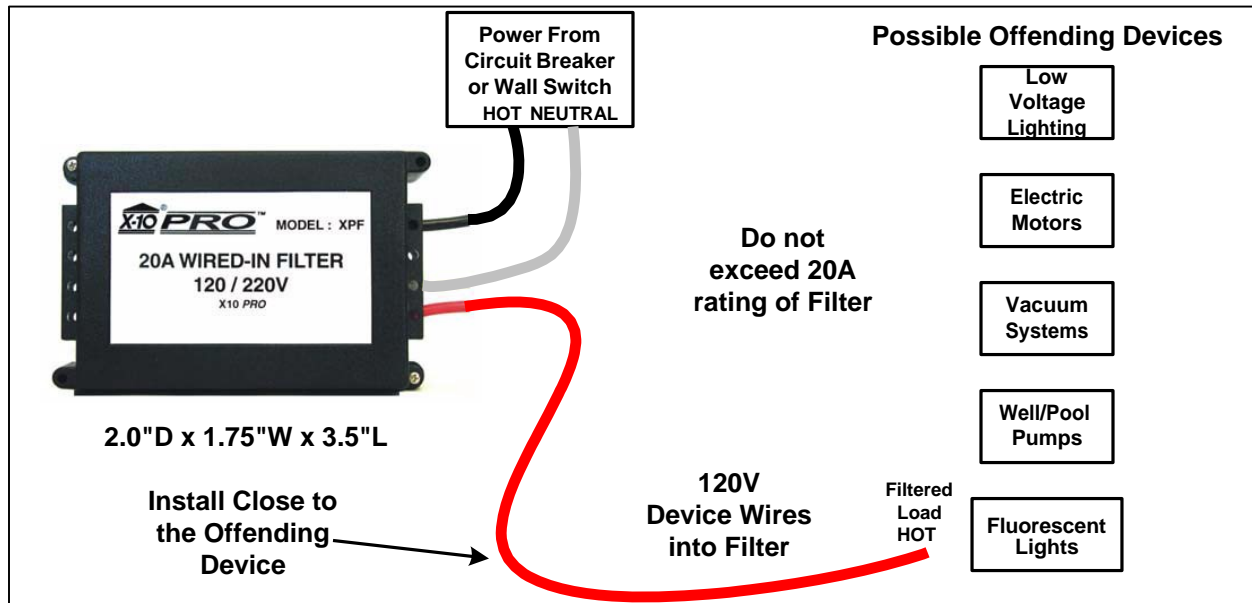

Description: The X10 PRO Wire-In Filter is designed to reduce electrical noise (on power wires) generated from the power supply of an electronic device. When you see a signal increase (improved operation) upon un-powering an electronic device, then you have detected an offending device (noise generating). Now all that you have to do is purchase an XPF Wire-in Filter. The XPF should be wired as close to the offending device as possible. The X10 Signal will now pass freely throughout the house power system without interference from the electrical noise, which is now reduced by the XPF Filter.

The above drawing is a simple representation of the XPF's basic elements of installation. See Page 2 for Specific Application Schematics.

Note: Filters must always be located as close to the offending device as possible.

Specific Requirements: 120VAC/20A max.
Dimensions 2.0"D x 1.75"W x 3.5"L fits in a three gang box.

Optional / Supplementary Devices & Modules:

XPCR - to ensure full X10 Signal Strength on both electrical 120V phases.
XPPF - Noise Filter rated at 5A and is used for "Plugged-in" configurations.

Electrical Protocol:

Nearly all residential homes are wired SPLIT-PHASE. Each 120V Phase is NOT directly connected with the other 120V phase. If after installation, an X10 Receiver does not respond to a remote Controller, then check to ensure that the breaker serving the X10 Receiver is on the same phase as the Controller. If not, the breaker can be changed to the opposite phase. An alternative solution is recommended, to install a Phase Coupler for improving remote communications throughout the home. See www.x10pro.com, then select Technical Support and PLC Troubleshooting.

Installation:

1. Determine which electronic device is producing electrical noise, causing an X10 remote-controlled item (light, etc.) to become inoperative.
2. Turn Power OFF, Wire-in the XPF Filter between the power wire and **as close to** the offending device. Do Not exceed 20Amp rating.
4. Retry operating the X10 remote-controlled item (light, etc.), previously inoperative, it should now be functional.

Determining Offending Device:

1. Always Un-plug/Un-power suspect electronic devices, turning-off is not sufficient as device power supply may still be ON in the idle mode.
2. Un-plug/Un-power one device at a time, retrying X10 Control each time.

Possible Wired-in Offending Devices:

Well/Pool Pumps, Electric Motors, Vacuum Systems, Fluorescent Lights (Tube or Bulbs), Low Voltage Lighting. Typically these devices would have an electronic power supply or control board producing the line noise.

Tech Tip: See PLC Troubleshooting document, at www.x10pro.com, then select Technical Support. This literature will offer in-depth problem solving techniques using the X10 PRO Test Equipment, Phase Couplers and Filters.

Wire-in Filter 20A

XPF

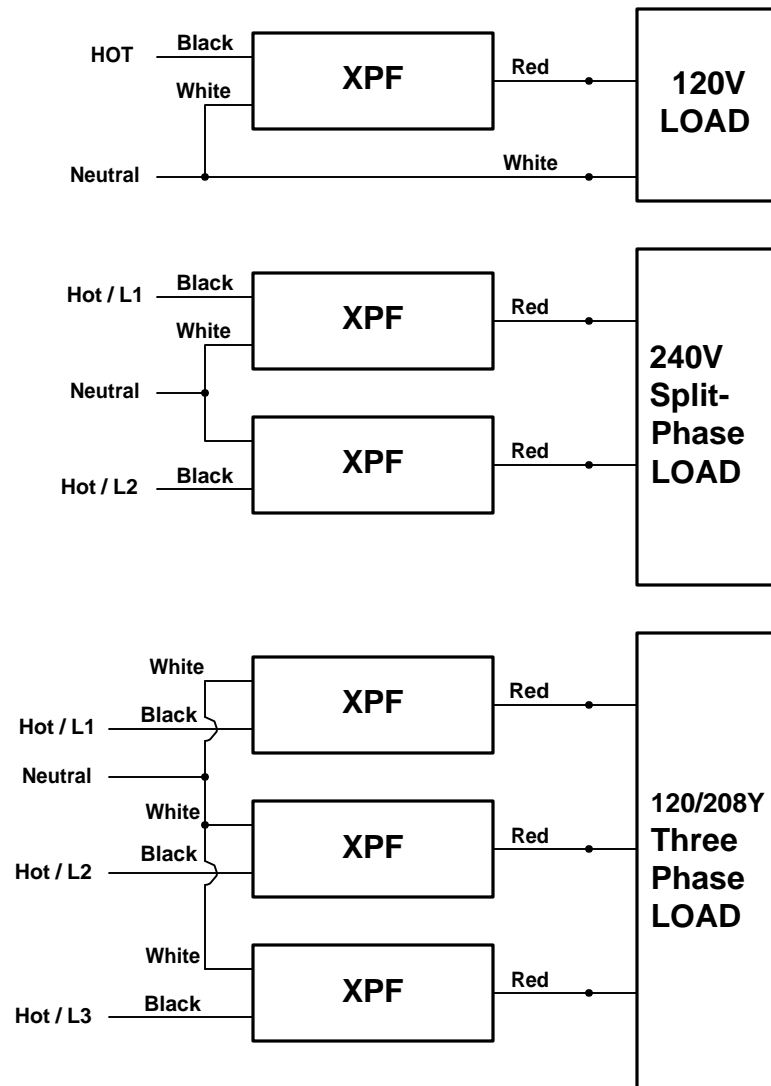

Three Load Types

1. 120V Load - standard load for all 120V devices
2. 240V Load - standard load for all 240V devices such as Pumps, Motors, Vacuum Systems.
3. 120/208Y 3-Phase Load - special high power devices such as Pumps and Motors.

Wire according to the above schematic diagram for the power system in use.

TWO YEAR LIMITED WARRANTY thehomeautomationstore.com (THAS), a division of Authinx Inc., warrants this product to be free from defective material and workmanship for a period of two years from the original date of purchase at retail. THAS agrees to repair or replace, at its sole discretion, a defective product if returned to THAS within the warranty period and with proof of purchase. If service is required under this warranty:

Call 1-888-423-8972, visit www.thehomeautomationstore.com, or email info@thehomeautomationstore.com